



Medicinal Chemistry/ CHEM 458/658

Chapter 6- Drugs from Natural Sources

Bela Torok

Department of Chemistry
University of Massachusetts Boston
Boston, MA

Introduction

- Ethnopharmacology – traditional herbal medicines

e.g. coca leaves (*erythroxyllone coca*)

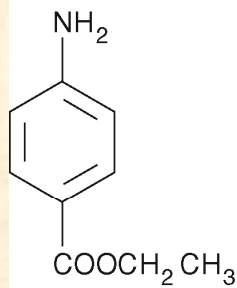

Benzocaine

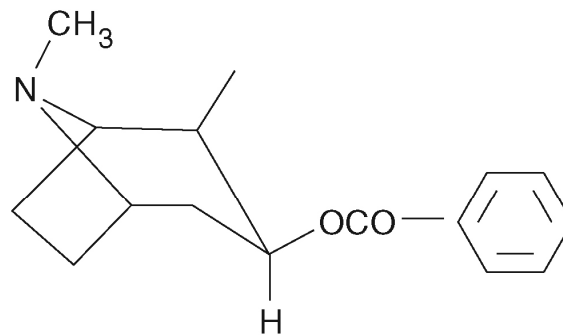

Cocaine

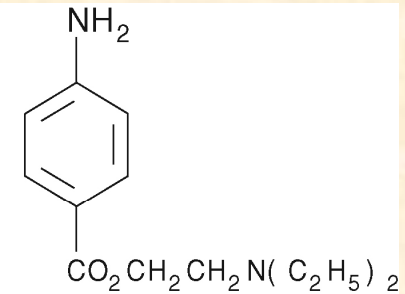

Procaine

Introduction



- Isolation

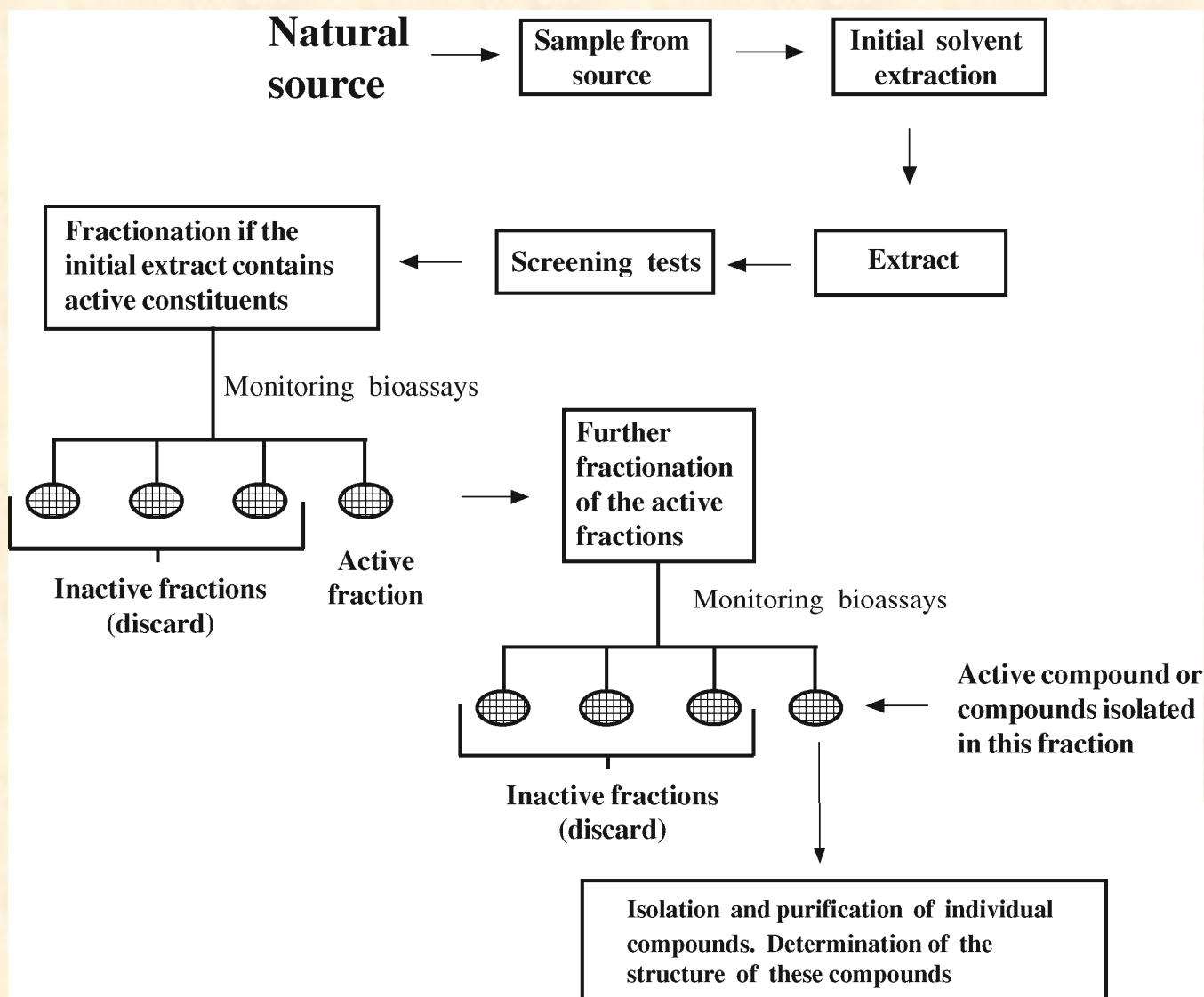

Bioassays



- Screening tests
 - rapid
 - accurate, reproducible
 - high capacity
 - cheap and easy

Specific

Broad assays

Bioassays – Screening Tests



- Whole organism screening tests
 - from microorganism to humans

(1) BSLT (Brine Shrimp Lethality Test)
uses brine shrimp (*Artemis salina*)

10 shrimps in 5 mL brine solution, results: LD₅₀ or LC₅₀



Bioassays – Screening Tests

(2) The crown gall tumor inhibition test

inhibition of crown gall tumors

(0.5 cm discs from potato tubers)

initiated by *Agrobacterium tumefaciens* (since 1977)



- Cultured cell tests
 - Sea star or sea urchin test

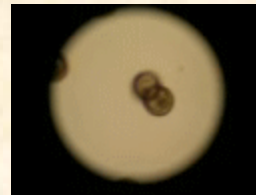

fertilized eggs – result: cell death – DNA, RNA synthesis inhibitors
microtubule or protein synthesis inhibitors

- Mammalian cell lines

Bioassays – Screening Tests

- Isolated enzyme tests
activates or inhibits the enzyme

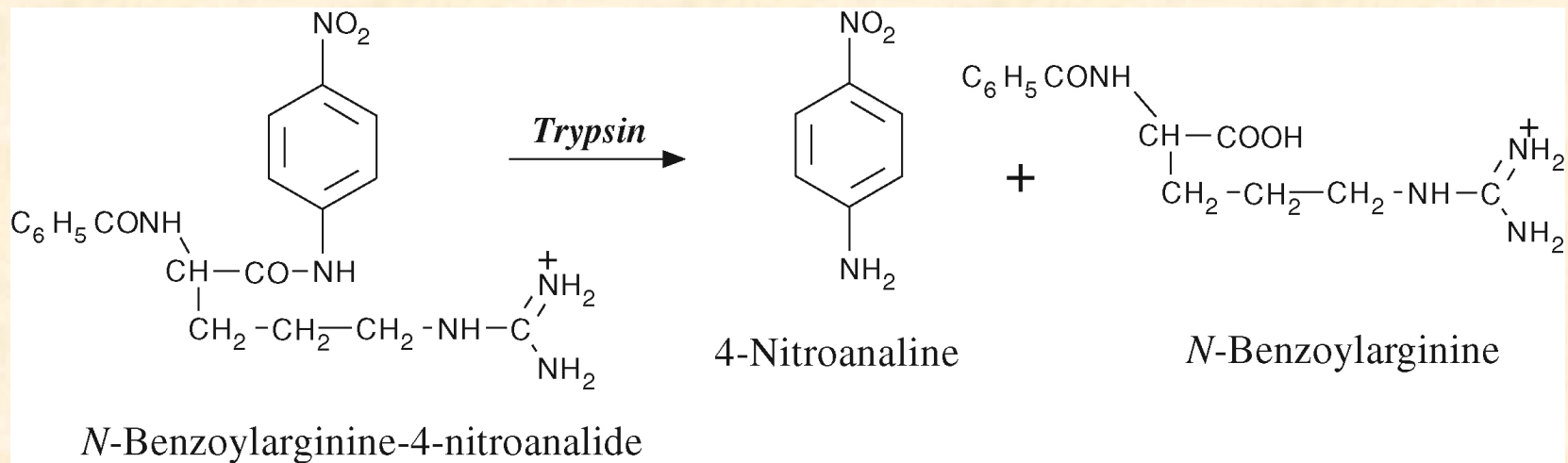

Bioassays – Screening Tests

- Isolated tissue tests
 - atomic coordinates (twist, bend, stretch etc.)
 - conformational analysis

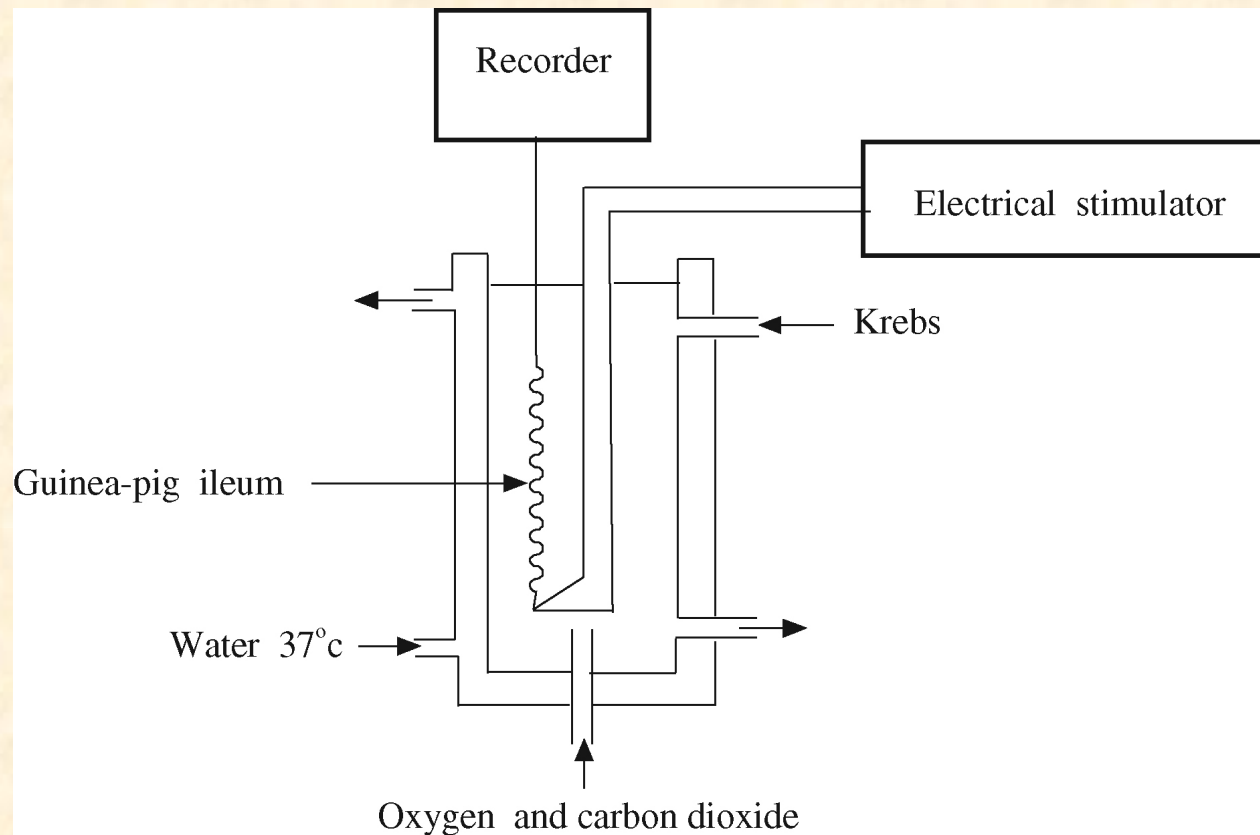

Bioassays – Monitoring Tests

- Same tests
- Activity change due to decomposition
- Activity change due to synergy

against
Myeloma

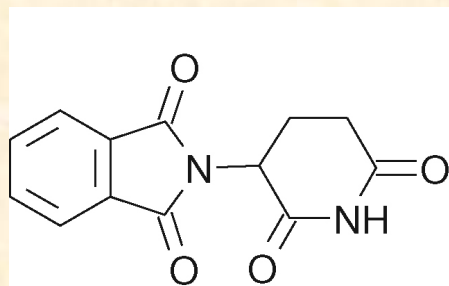

Thalidomide

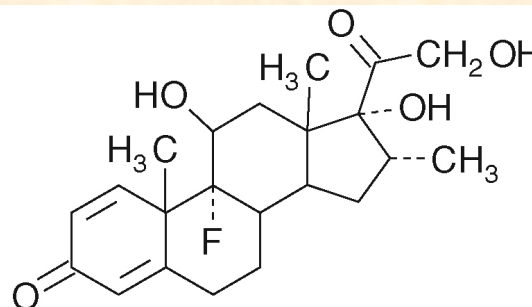

Dexamethasone

- Activity change due to fractionation loss

Dereplication

- Use of chemical techniques to eliminate known compounds from the isolated extract.

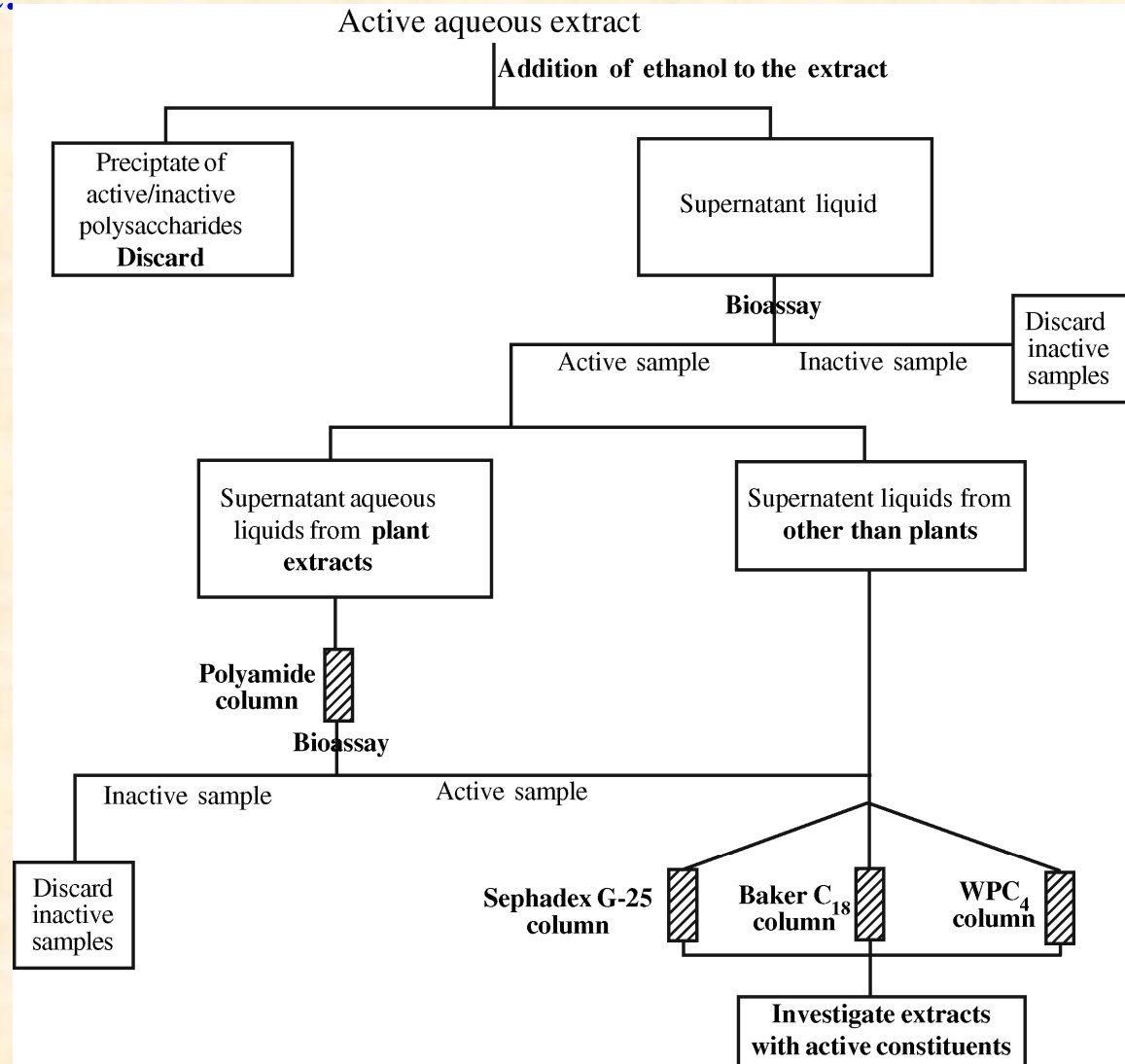

Dereplication

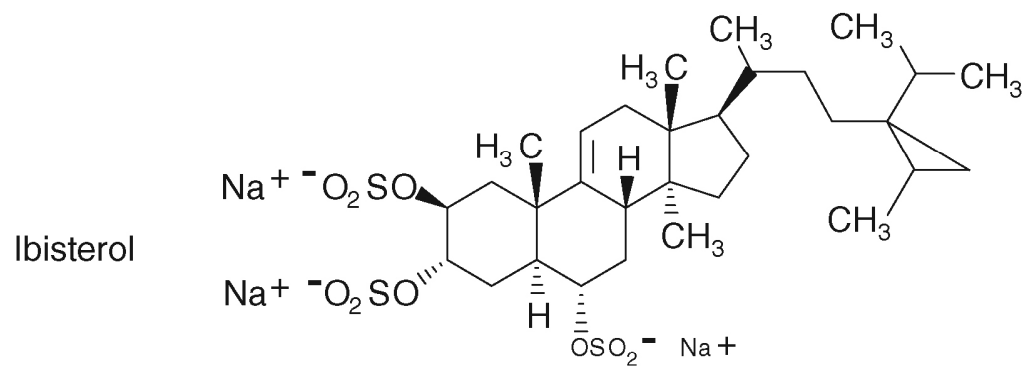
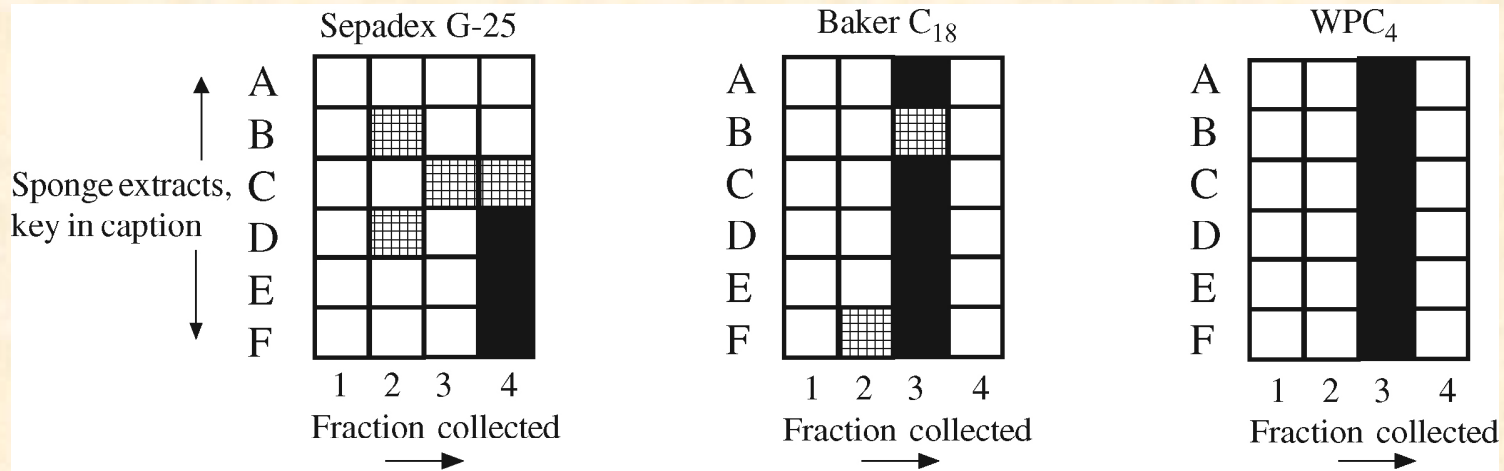

Structural Analysis of the Isolated Substance



- Purity
Chromatographic techniques

- Identification
NMR
IR
MS
and their combination with chromatographic techniques

Active Compound Development

- A case study

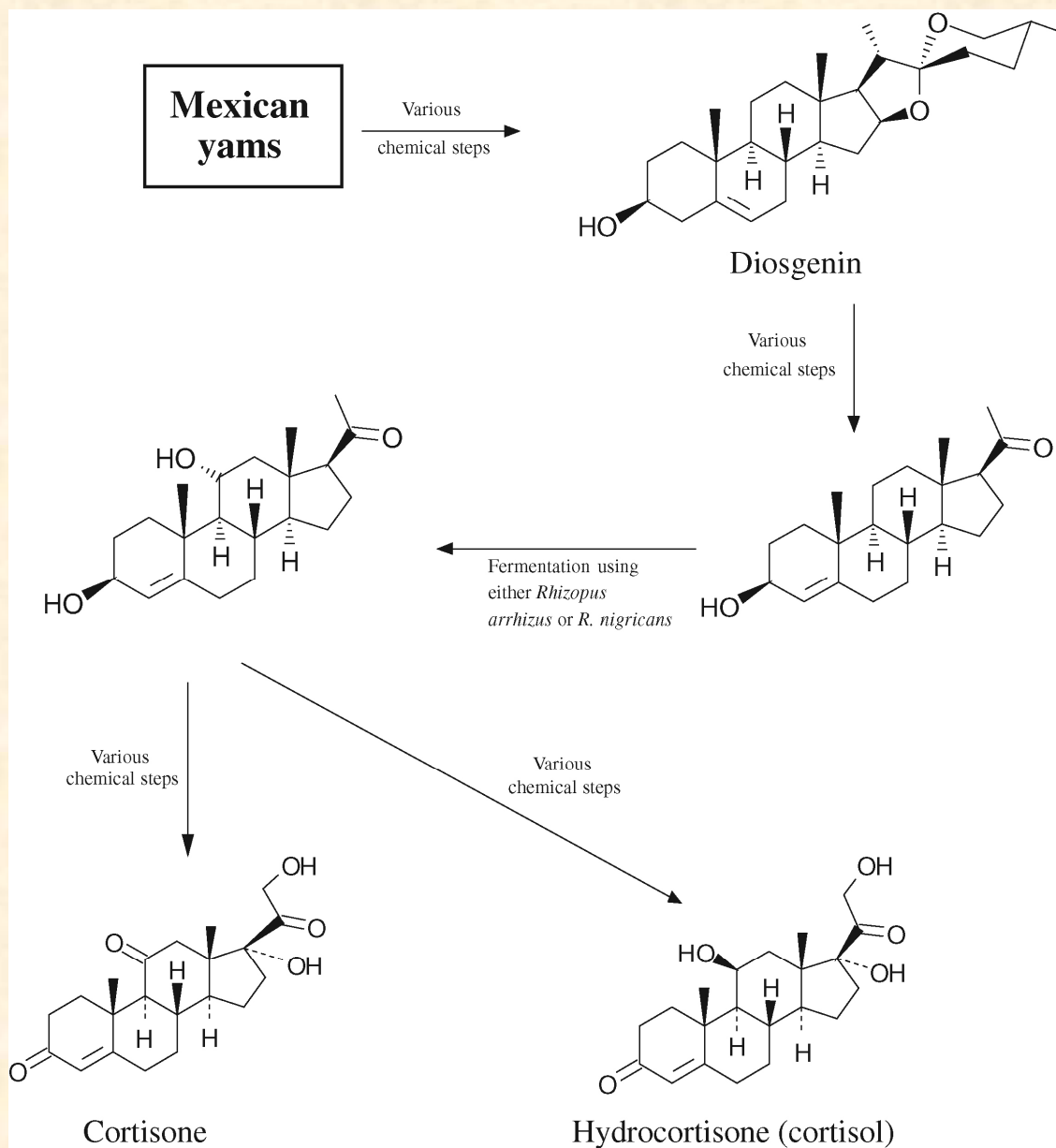

Extraction Procedures



- General considerations

Low polarity solvents (small hydrocarbons, CHCl_3 , ether etc.)
fats, waxes, oils, alkaloids,

High polarity solvents (EtOH, H_2O)
amino acids, sugars, glycosides

Extraction with an
aqueous base B



Regeneration step of
the original form of
the constituent

Extraction with an
aqueous acid HX



Extraction Procedures

- Commonly used extraction methods
 - Solvent-based methods

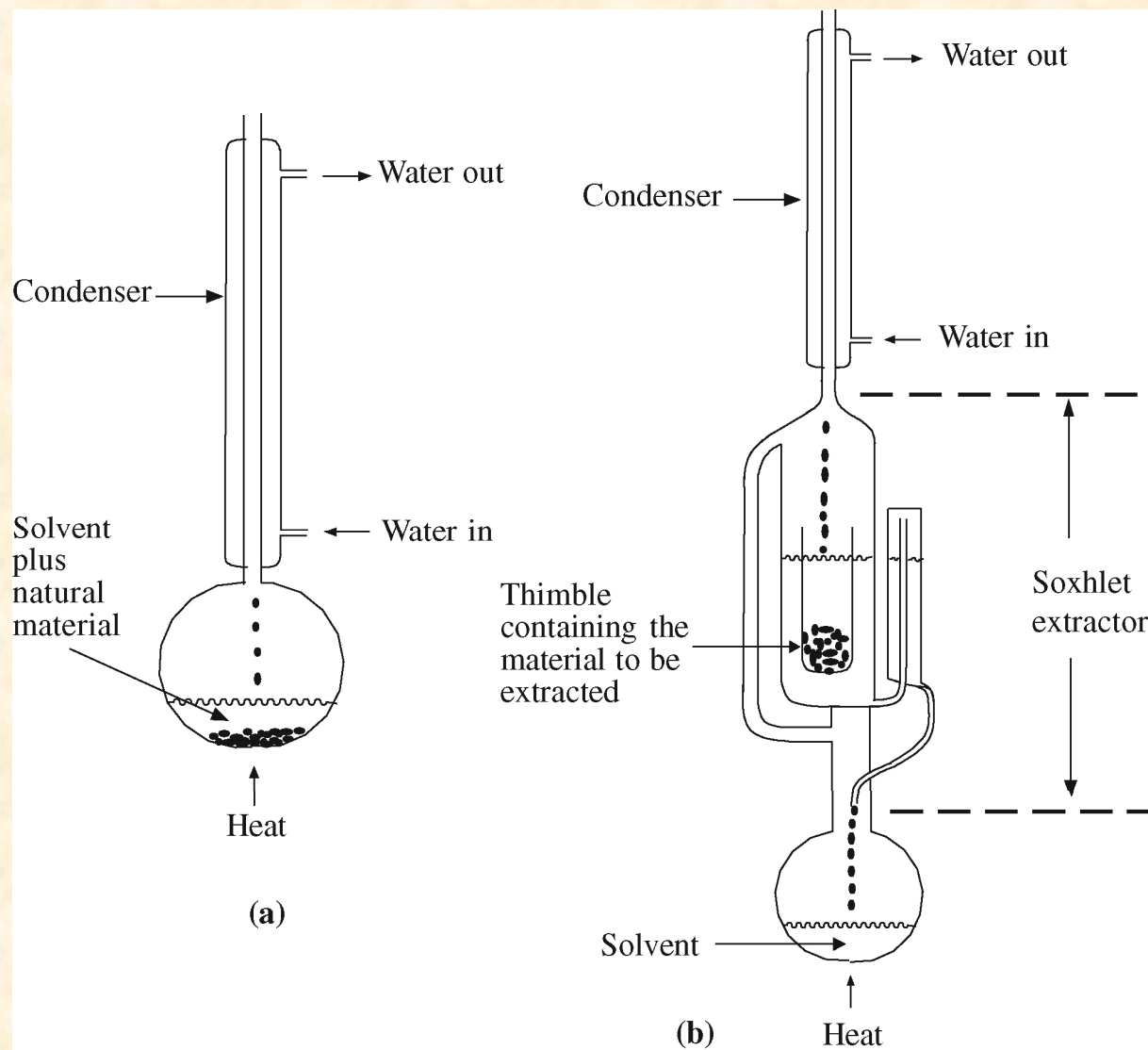

Extraction Procedures

- Commonly used extraction methods

Solvent-based methods

- Steam distillation
- supercritical fluid extraction

Supercritical Fluids: CO₂ Phase Diagram

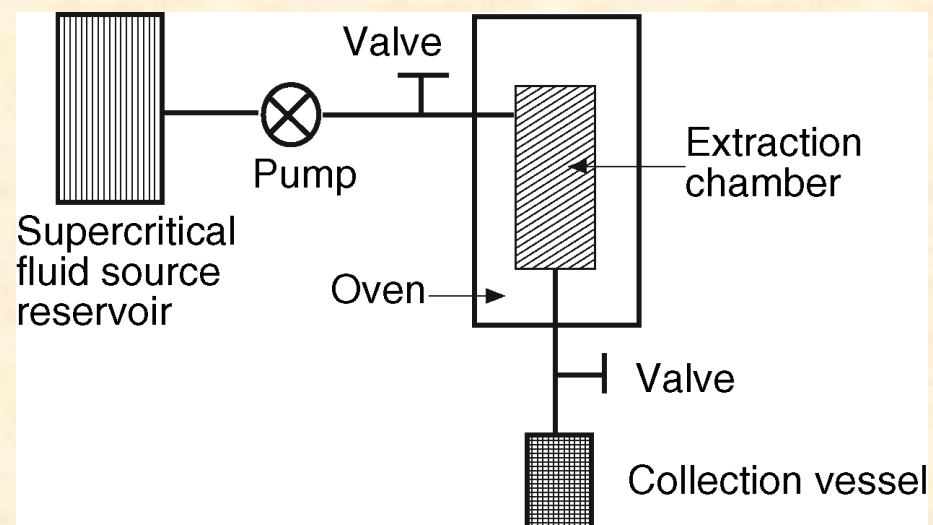
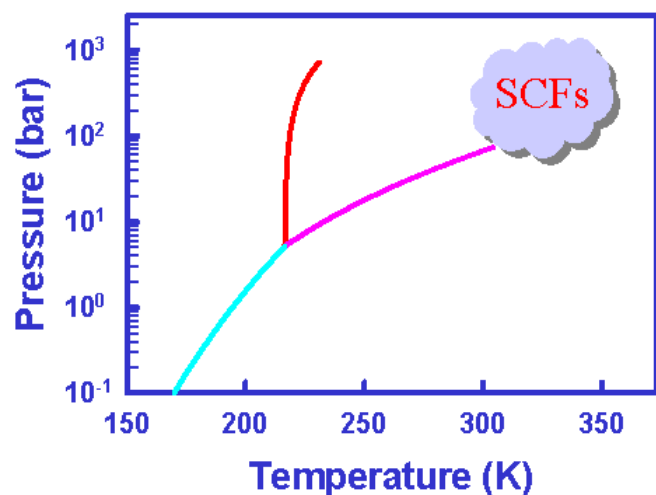

Extraction Procedures



- Cleaning up procedures
 - precipitation
 - partition (extraction)
 - gel filtration
 - chromatography
 - dialysis

Fractionation Methods

- Same techniques used in extraction can be used here
 - liquid/liquid partition

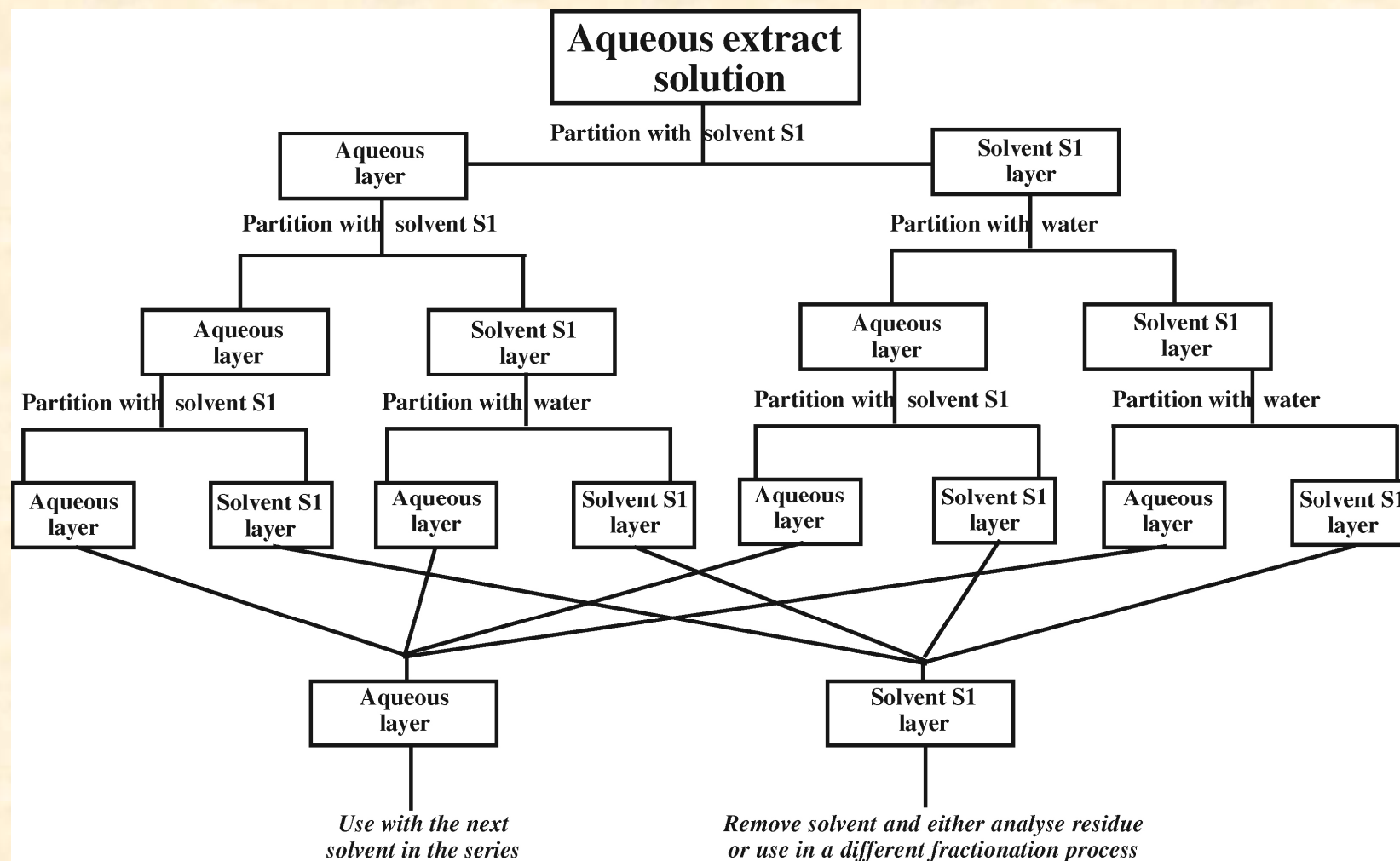

Fractionation Methods



- Same techniques used in extraction can be used here
 - liquid/liquid partition

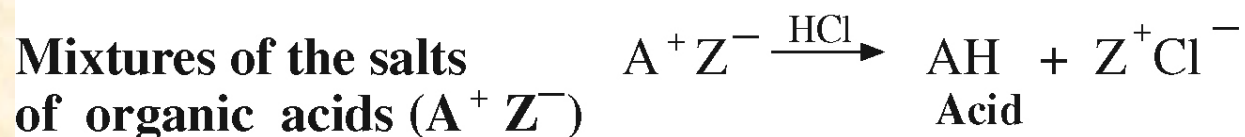
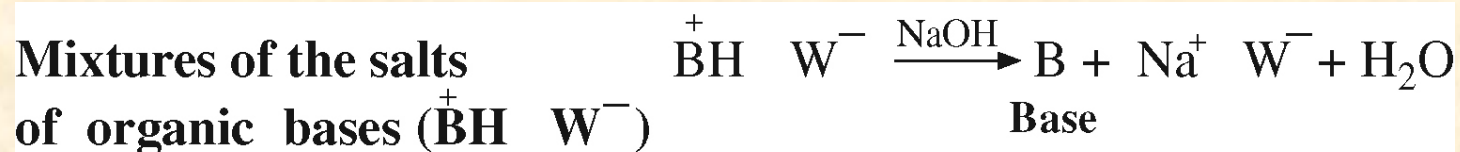

- CCCD (Craig counter-current distribution)
- SSD (steady-state distribution)
- salting out

Fractionation Methods



- Chromatographic Methods

Liquid phase Chromatography (LC)

- Liquid/Solid (or adsorption)
- Ion (IC)
- Size exclusion (SEC)
- Liquid/Liquid (or partition) (LLC)
- Liquid/bound phase

Thin Layer Chromatography (TLC)

Gas phase Chromatography (GC)

- Gas/Liquid (GLC)
- Gas/Solid (GSC)

Supercritical Fluid Chromatography (SFC)

- Gas/Liquid (GLC)
- Gas/Solid (GSC)

Fractionation Methods



- Precipitation
- Distillation
- Dialysis
- Electrophoresis

Case Study : Taxol

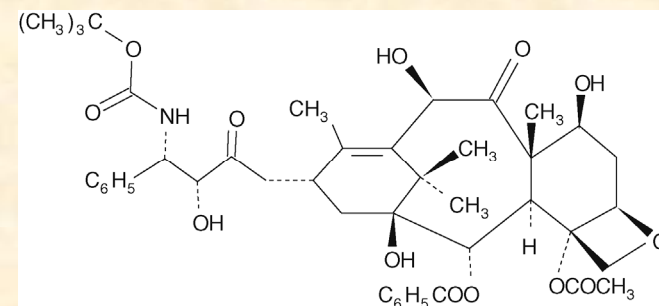
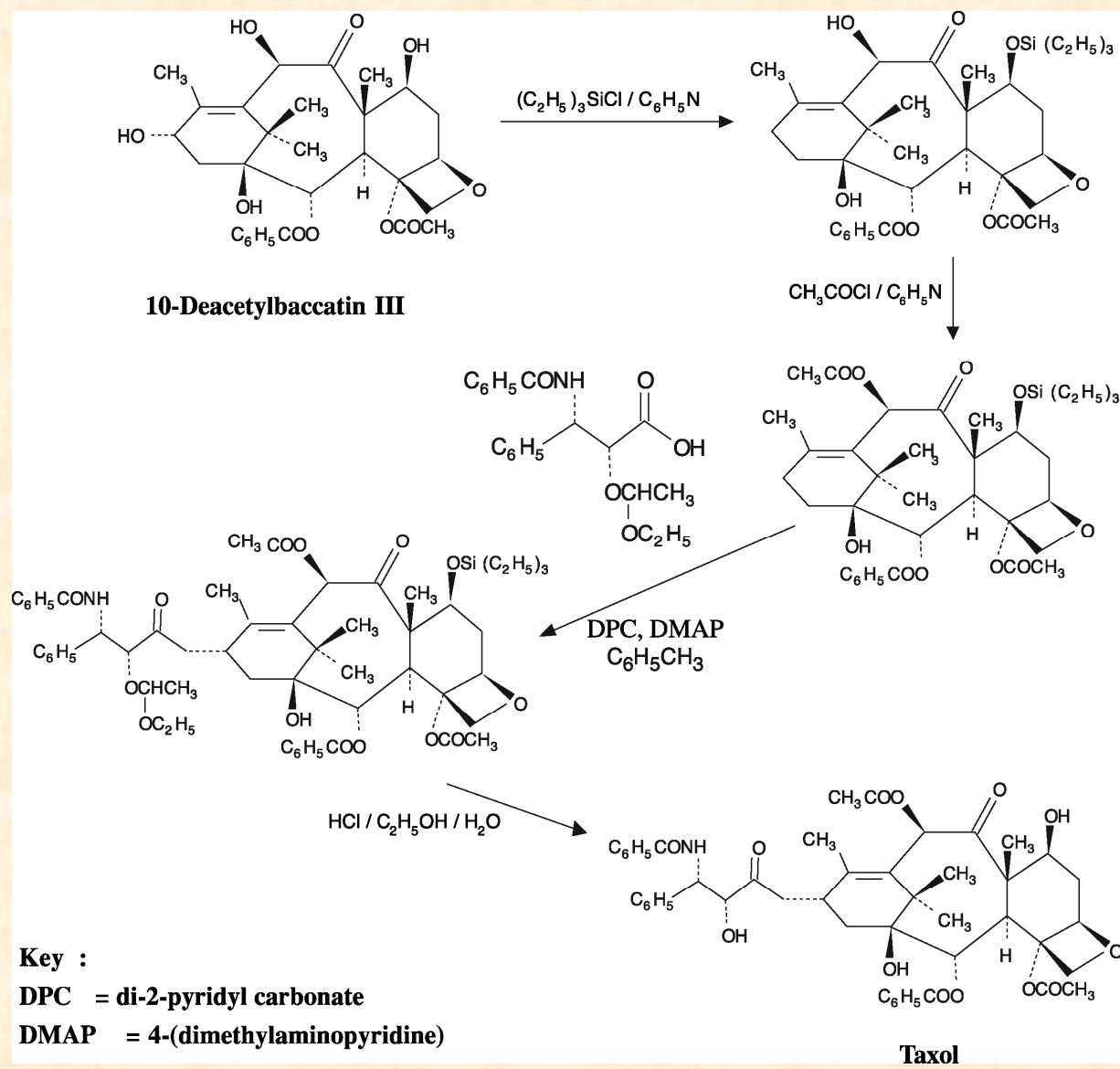

Taxotere

Key :
DPC = di-2-pyridyl carbonate
DMAP = 4-(dimethylaminopyridine)