

Fundamental inorganic electrochemistry

- potential sweep voltammetry

- Potential (*aka voltammetric*) sweep methods are the most common electrochemical methods in use by chemists today as they provide an efficient and straightforward assessment of the redox behavior of molecular systems.
- In all potential sweep methods, the potential (V) of the working electrode is varied continuously with time according to a predetermined potential waveform (*aka excitation function*), while the current (I) is concurrently measured as a function of the potential.
- The applied potential at the working electrode is measured against a reference electrode of choice, while a counter (*aka auxiliary*) electrode is required to balance the I - V applied.

i.e. three electrodes are required: working, reference and counter. An electrolyte salt must also be dissolved in solution to maintain sufficient conductivity in the bulk solution.
- Potential sweep methods include the following experiments:
 - Linear sweep voltammetry (*LSW*)
 - Cyclic voltammetry (*CV*)
 - Differential pulse voltammetry (*DPV*)
 - Square wave voltammetry (*SWV*)
 - Controlled potential electrolysis (*aka bulk electrolysis. BE*)

Common electrodes

Working electrode

- Glassy carbon
- Platinum
- Silver
- Gold



Counter electrode

- Pt wire
- Glassy carbon rod



Reference electrode

(physically but not electrochemically isolated with a porous vycor frit)

- Ag/AgCl 3 M aq. KCl
- Normal Hydrogen Electrode (NHE)
- Saturated Calomel Electrode
- Ag/AgNO₃ (0.01 M acetonitrile)

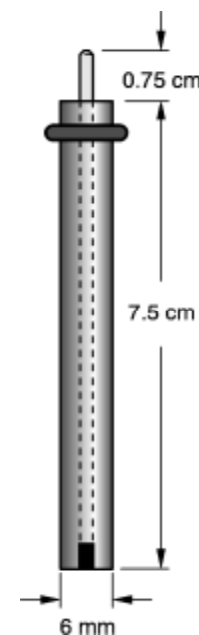

Linear sweep voltammetry

- Linear sweep voltammetry represents the most basic potential sweep method.
- In LSV the potential of the working electrode is varied linearly with time between *two values* *i.e.*, the initial (E_i) and final (E_f) potentials.
- As the electrode potential is constantly rising (*or decreasing*) throughout the experiment, a level of capacitive (*aka ohmic*) current flows continuously. These currents are due to the capacitive charging of the working electrode's double layer (*see next slide*).
- Faradaic current will also flow when the potential reaches values at which the species in solution can undergo electrochemical conversions.

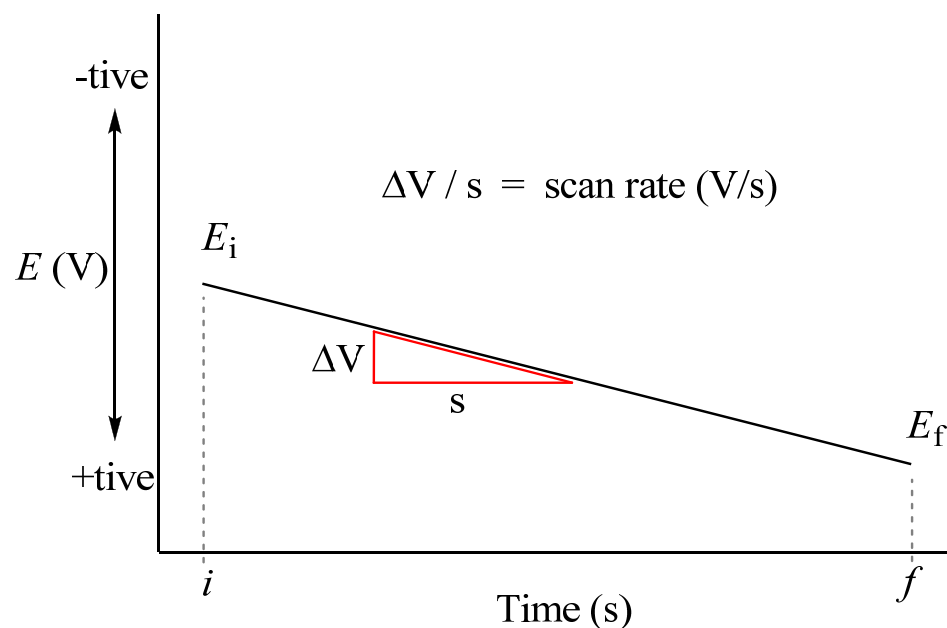

Excitation function (*potential waveform*) for a LSV experiment



Linear sweep voltammetry

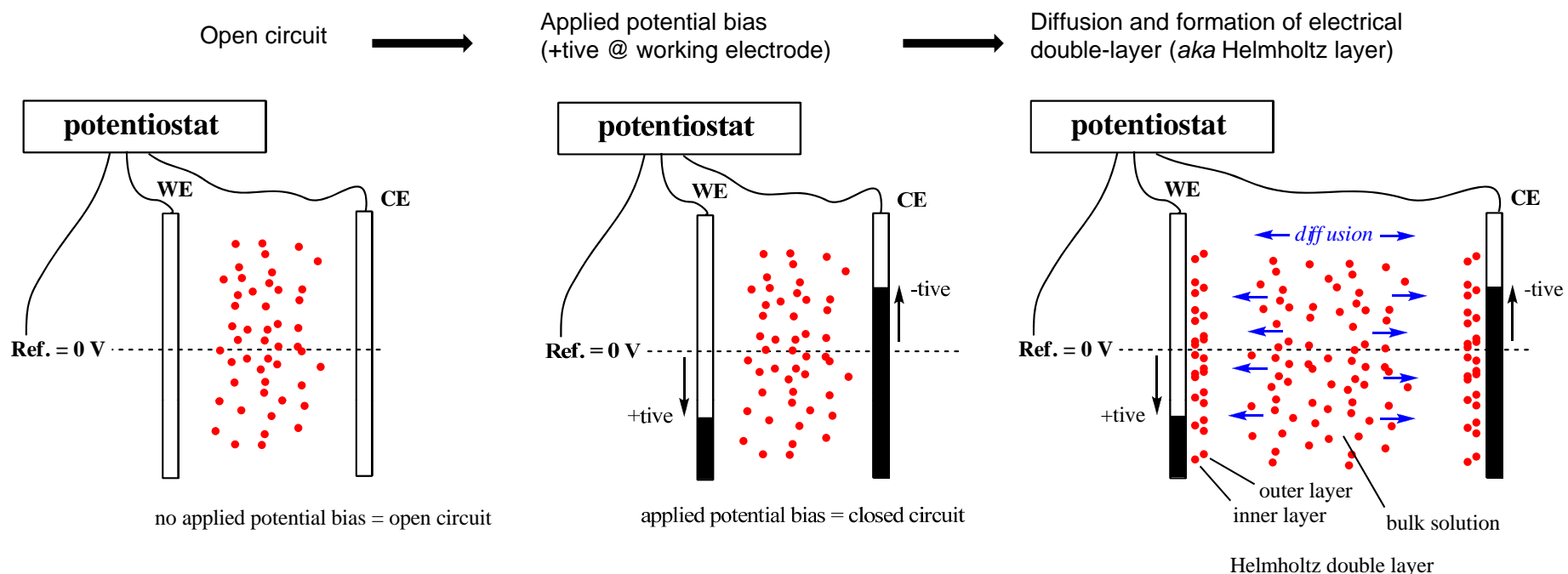

- Relative to bulk solution redox chemistry only occurs in the electrical double layer.

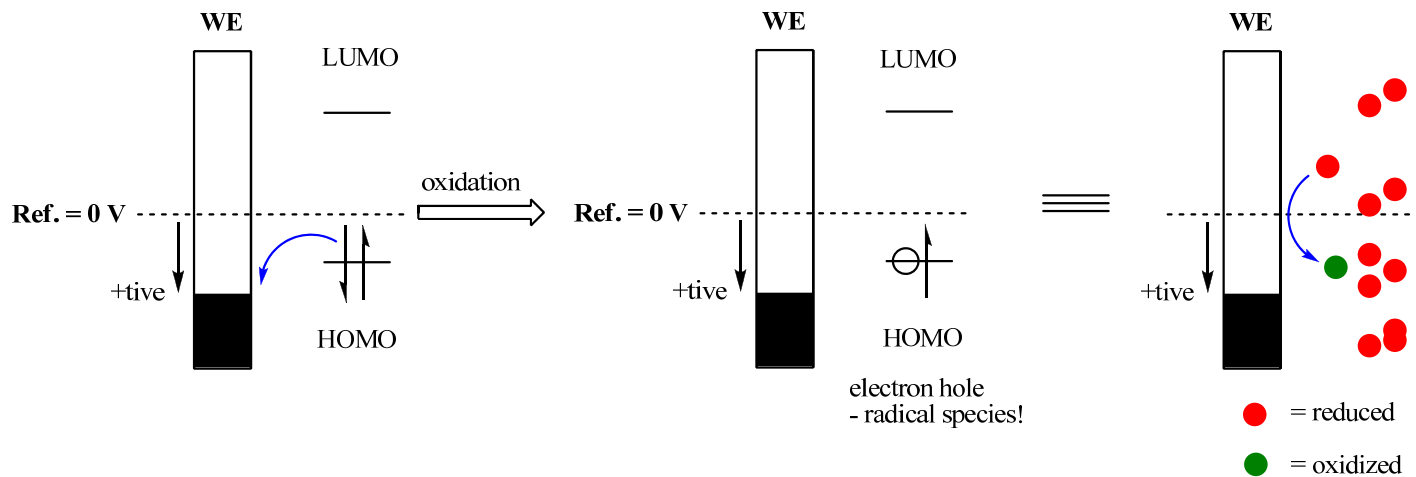

Linear sweep voltammetry of ferrocene

- The $\text{Fe}^{\text{III/II}}$ couple of ferrocene, $(\eta^5\text{-C}_5\text{H}_5)_2\text{Fe}$, is an example of a well-behaved electrochemically reversible system in acetonitrile solution and is often used as an internal or *pseudo reference* when reporting formal potentials of inorganic/organometallic complexes.
- For example, taking a 1 mM solution of ferrocene under the following conditions:
 - Working electrode = 3 mm diameter glassy carbon
 - Counter electrode = Pt wire
 - Reference electrode = Ag/AgCl 3 M aq. KCl
 - Electrolyte = 0.1 M Bu_4NPF_6 in acetonitrile
- The voltammetric scan is started at a potential at which no electrochemical reactions may take place, that is, $E < E_{1/2}$.
- *Scanning the potential* linearly scanned in the positive direction gives rise to a faradaic currents upon oxidation of the Fe(II) center to Fe(III)
- Importantly, the solution is kept is kept quiescent, i.e. not stirred, so that diffusion is the only mass transport mechanism possible.
- If the redox couple is electrochemically reversible a characteristic cathodic wave is observed with a maximum current value given by the Randles-Sevcik equation.

Linear sweep voltammetry of ferrocene

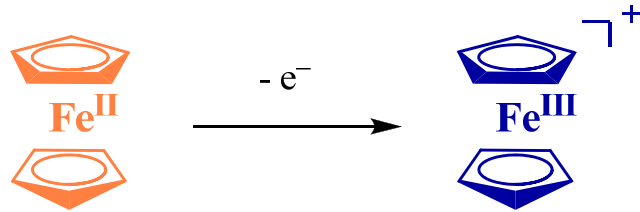

Ferrocene

Ferricenium ion

Randles-Sevcik equation:

$$i_p = (2.69 \times 10^5) n^{2/3} A C_{Ox} (D_{Ox} \nu)^{1/2} \quad \text{at } 25^\circ \text{C}$$

i_p = peak current; n = # electrons;

A = electrode area; C = concentration; ν = potential

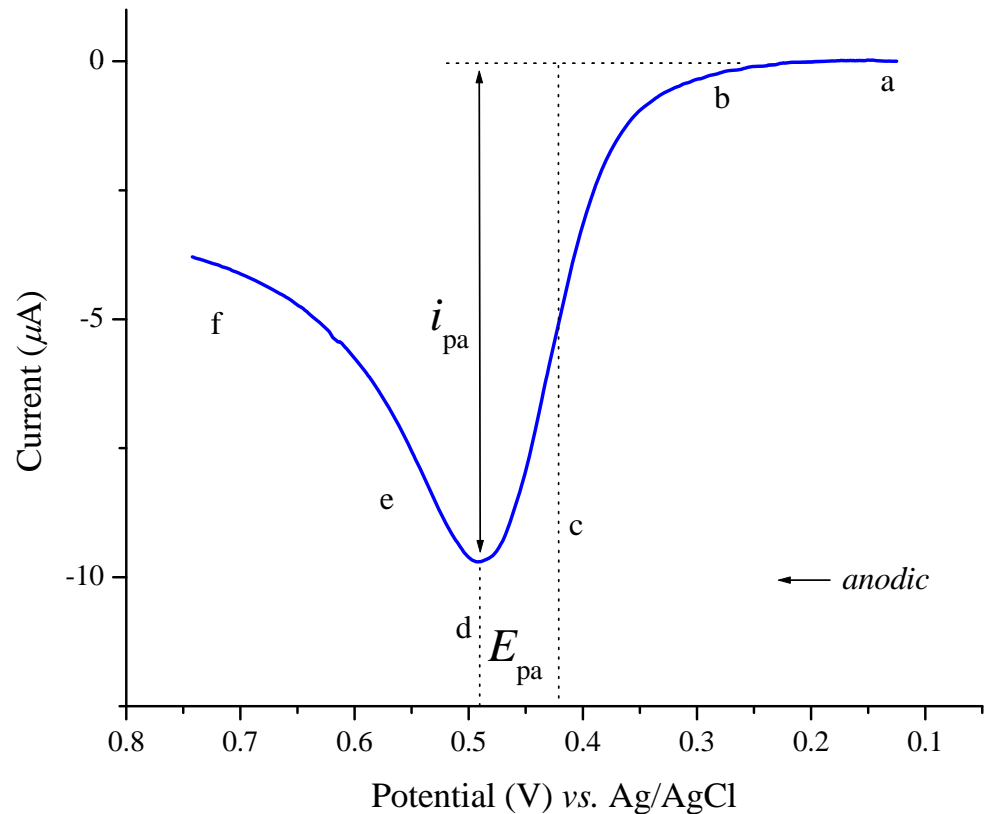
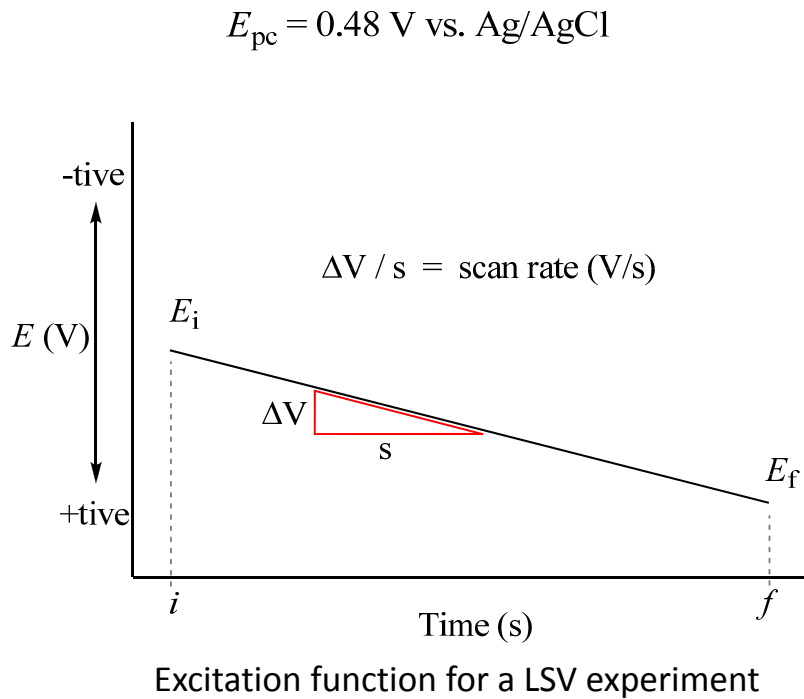

1 mM ferrocene (3 mm glassy carbon; 0.1 M Bu_4NPF_6 acetonitrile; Pt wire; Ag/AgCl 3M aq. KCl)

Linear sweep voltammetry of ferrocene

- The initial potential at 0.10 V shows no current and therefore no electrolysis when the electrode is switched on.
- The electrode is scanned toward a more positive potential.
- As the potential is made more positive the electrode is now a sufficiently strong oxidant to oxidize the ferrocene to ferrocenium.
- The concentration of ferrocene decreases rapidly at the electrode surface as the anodic current increases. At point *d* the concentration of ferrocene is substantially diminished causing the current to peak.
- The current now decays as the ferrocene concentration becomes more depleted and ferricenium surrounds the electrode.
- Complete oxidation is ensured by scanning to 0.75 V.

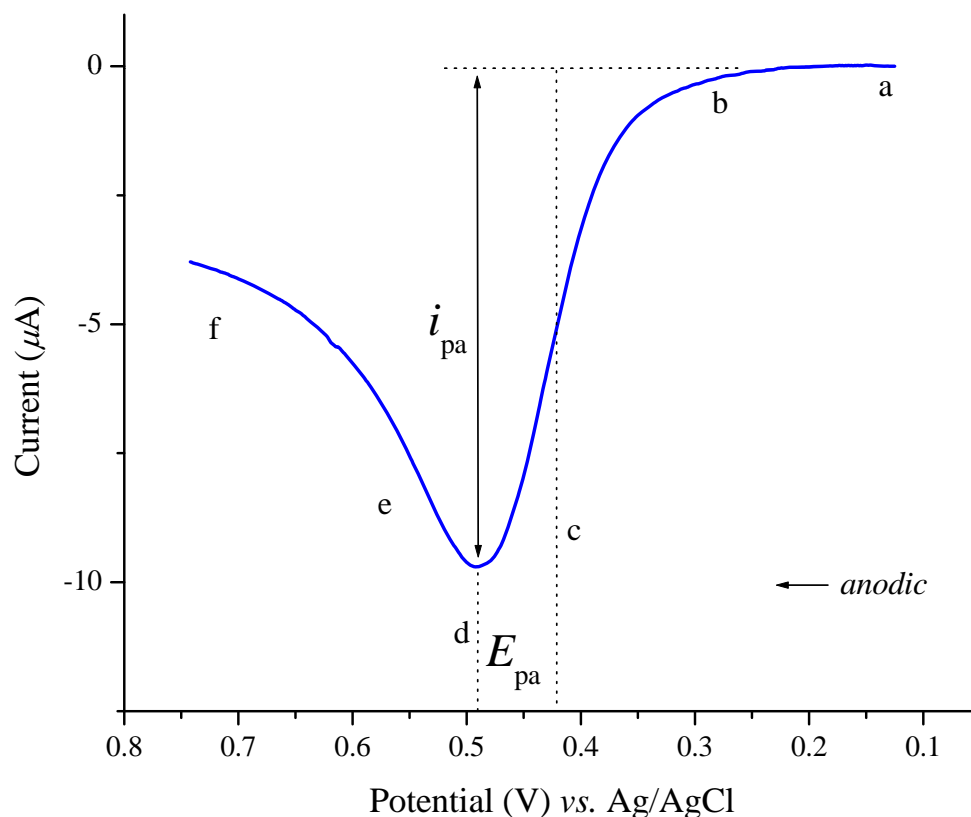

Important notes on LSW

- Note: E_{pa} does not equal the half-wave potential of the corresponding redox couple.
- For reversible electrochemical couples the anodic peak E_{pa} occurs *ca.* 30 mV more positive than the $E_{1/2}$ value and its position is independent of the scan rate, whereas the cathodic peak E_{pc} occurs *ca.* 30 mV more negative than the $E_{1/2}$ value.
- The position of both E_{pa} and E_{pc} are independent of the scan rate but $i \propto t^{1/2}$.
- The position of the peak represents the onset of diffusion control on the current.
- That is, beyond the peak potential the current does not depend on the potential anymore and is fully controlled by the rate of diffusion, which decreases gradually as the thickness of the diffusion layer increases.
- For slower (irreversible) electrochemical couples, a peak may or may not be reached.
- If the voltammogram exhibits an irreversible peak, the corresponding peak potential will shift anodically for E_{pa} as the scan rate increases.

Cyclic voltammetry

- Cyclic voltammetry (CV) is based on the same principles as linear sweep voltammetry, however, in CV the potential of the working electrode is scanned back after reaching a chosen value, the so-called switching potential (E_{sp}).
- Thus, in CV the potential of the working electrode is varied linearly with time between *three values* i.e., $E_i \rightarrow E_{sp} \rightarrow E_f$.
- In fact, modern instruments allow the user to choose multiple switching potentials for carrying out tailored CV scans over a chosen potential window.

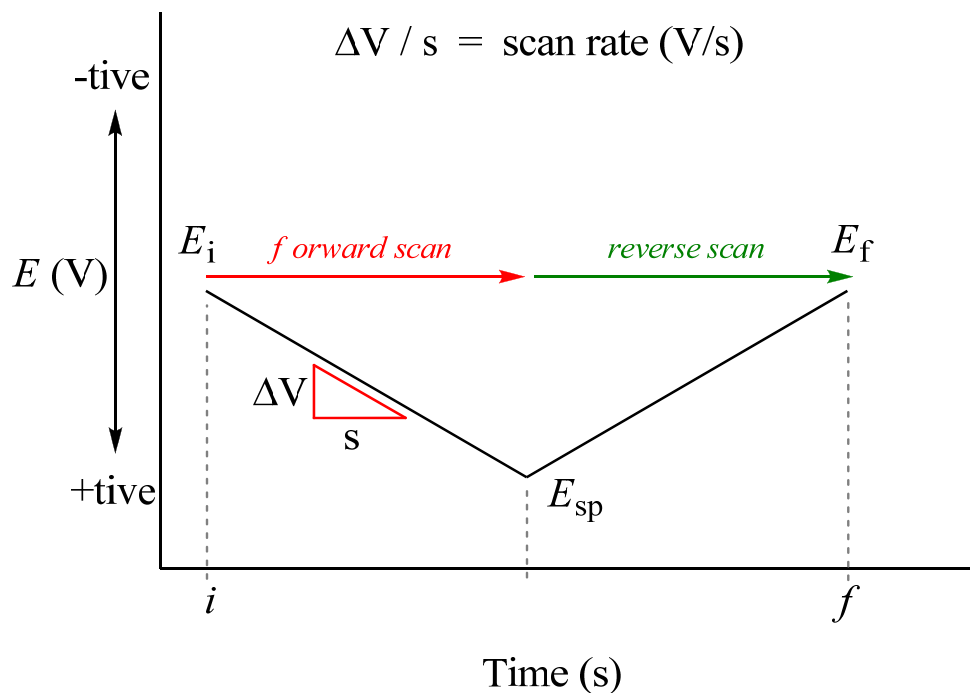

Excitation function (*potential waveform*) for a CV experiment



- One method to assess the reversibility of a redox couple is the evaluation of the potential difference between the peak potentials (ΔE_p) of the anodic and cathodic peaks associated with the couple.
- Based on numerical solutions of the current-potential response in CV experiments, a value of $59/n$ mV (at 25°C, first cycle voltammogram) is expected for a reversible redox couple.
- It is extremely important to realize that this value will only be obtained if the switching potential is at least 200 mV beyond the peak potential observed in the forward scan.
- The proximity of the switching potential to the voltammetric peaks leads to increased ΔE_p values.
- Furthermore, the presence of uncompensated cell resistance also leads to increased ΔE_p values., e.g. poor electrolyte conductivity, non-aqueous – aqueous junction potentials etc.
- The characteristic half-wave potential $E_{1/2}$ of a redox couple is typically within a few mV of the formal potential E° for the couple according to the Nernst equation where the ratio of the diffusion coefficients D_{Ox} and D_{Red} is usually very close to unity. The easy determination of half-wave potentials and estimation of formal potentials is an extremely attractive feature of CV.

$$E_{1/2} = E^{\circ'} - \frac{RT}{2nF} \ln \frac{D_{\text{Ox}}}{D_{\text{Red}}}$$

Cyclic voltammetry of ferrocene

1 mM ferrocene
 3 mm glassy carbon
 0.1 M Bu₄NPF₆ acetonitrile
 Pt wire
 Ag/AgCl 3M aq. KCl

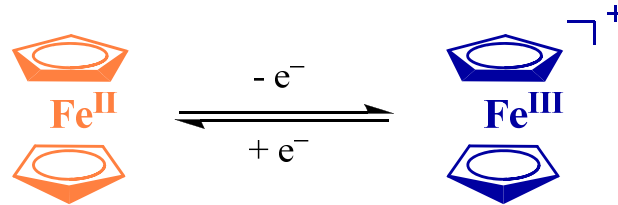

Ferrocene

Ferricenium ion

(vs. Ag/AgCl)

$$E_{pc} = +0.48 \text{ V}, E_{pa} = +0.42 \text{ V}$$

$$\Delta E = 60 \text{ mV}, E_{1/2} = 0.450 \text{ V}$$

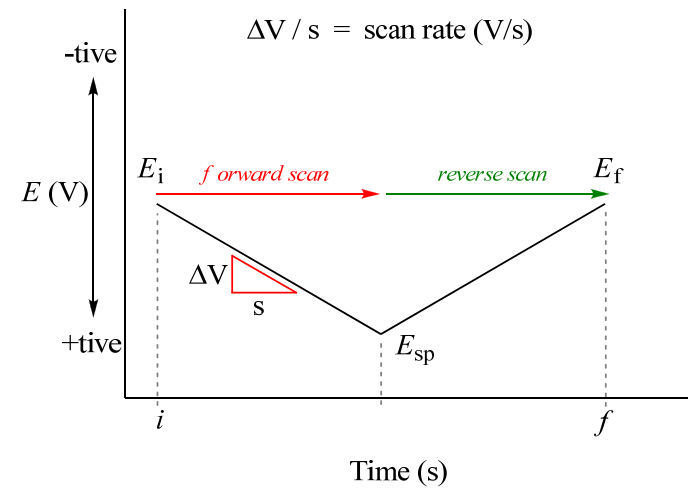
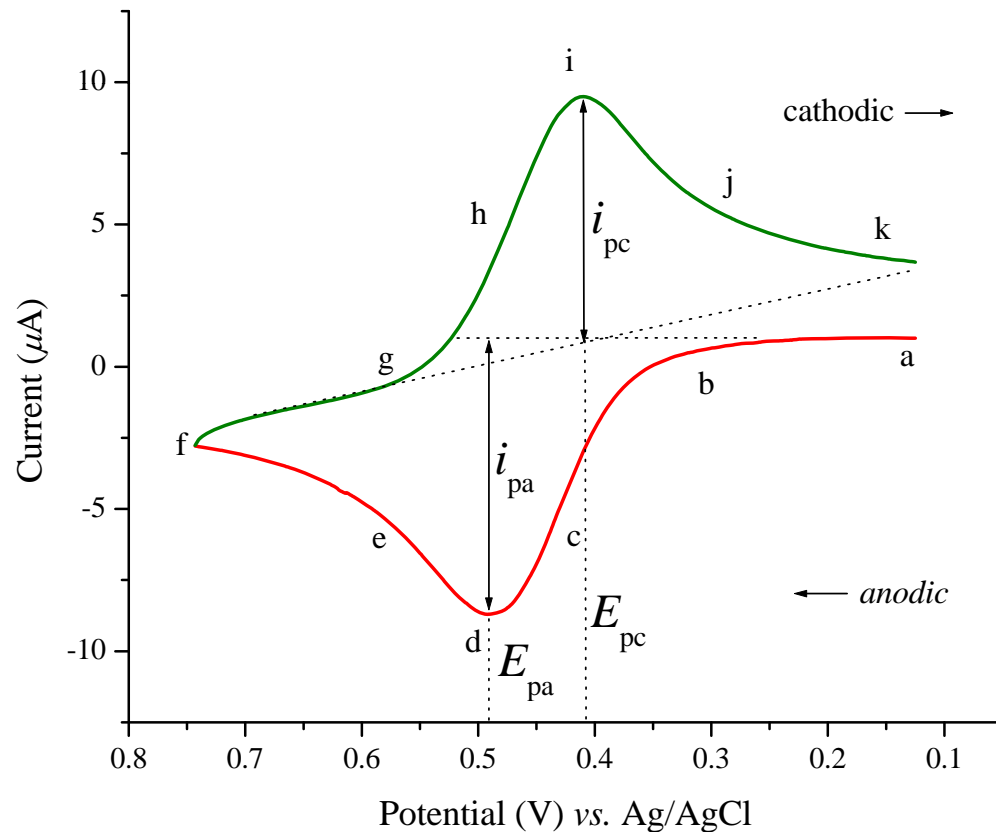

Linear sweep voltammetry of ferrocene

- a. The initial potential at 0.10 V shows no current and therefore no electrolysis when the electrode is switched on.
- b. The electrode is scanned toward a more positive potential.
- c. As the potential is made more positive the electrode is now a sufficiently strong oxidant to oxidize the ferrocene to ferricenium.
- d. The concentration of ferrocene decreases rapidly at the electrode surface as the anodic current increases. At point *d* the concentration of ferrocene is substantially diminished causing the current to peak.
- e. The current now decays as the ferrocene concentration becomes more depleted and ferricenium surrounds the electrode.
- f. The scan is then reversed at the switching potential E_{sp} of 0.75 V. Between points *f* and *g* the anodic current continues because the potential is still sufficiently positive to oxidize ferrocene.
- g. At point *h* the electrode is a sufficiently strong reductant to reduce ferricenium, which has accumulated adjacent to the electrode surface and the reaction: $[(\eta^5\text{-C}_5\text{H}_5)_2\text{Fe}^{\text{III}}]^+ + e^- \rightarrow (\eta^5\text{-C}_5\text{H}_5)_2\text{Fe}^{\text{II}}$ occurs at the electrode surface.
- h. Thus, the cathodic current rapidly increases to point *i* until the surface concentration of $[(\eta^5\text{-C}_5\text{H}_5)_2\text{Fe}^{\text{III}}]^+$ is diminished causing the current to peak. From point *i* to *j* the cathodic current decays as solution surrounding the electrode is depleted of $[(\eta^5\text{-C}_5\text{H}_5)_2\text{Fe}^{\text{III}}]^+$.

CV vs LSV

- The key advantage of CV over simple LSV results from the reverse scan.
- Reversing the scan after the electrochemical generation of a species is a direct and straightforward way to probe its stability.
- A stable electrogenerated species will remain in the vicinity of the electrode surface and yield a current wave of opposite polarity to that observed in the forward scan.
- An unstable species will react as it is formed and no current wave will be detected in the reverse scan.
- If the electrochemical process is relatively fast within the time scale of the experiment and the electrogenerated species, e.g. ferricenium, is perfectly stable in the electrolytic solution. Under these conditions, and assuming that the solution is kept quiescent during the experiment, the ratio of the cathodic and anodic peak currents (the peak currents measured in the forward and reverse scans, respectively) should be equal to one.
- Deviations from unity reveal the presence of chemical reactions involving either redox partner (Ox or Red) or both partners.
- The average of the two peak potentials affords the half-wave potential for the corresponding couple, i.e.

$$E_{1/2} = (E_{pa} + E_{pc}) / 2$$

Reference electrodes

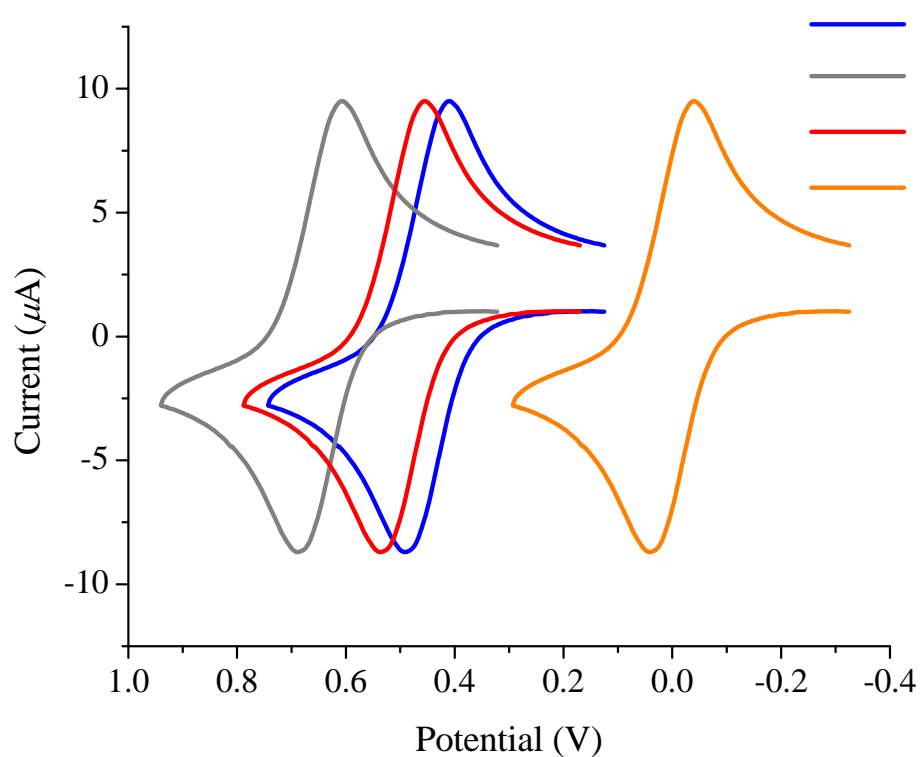
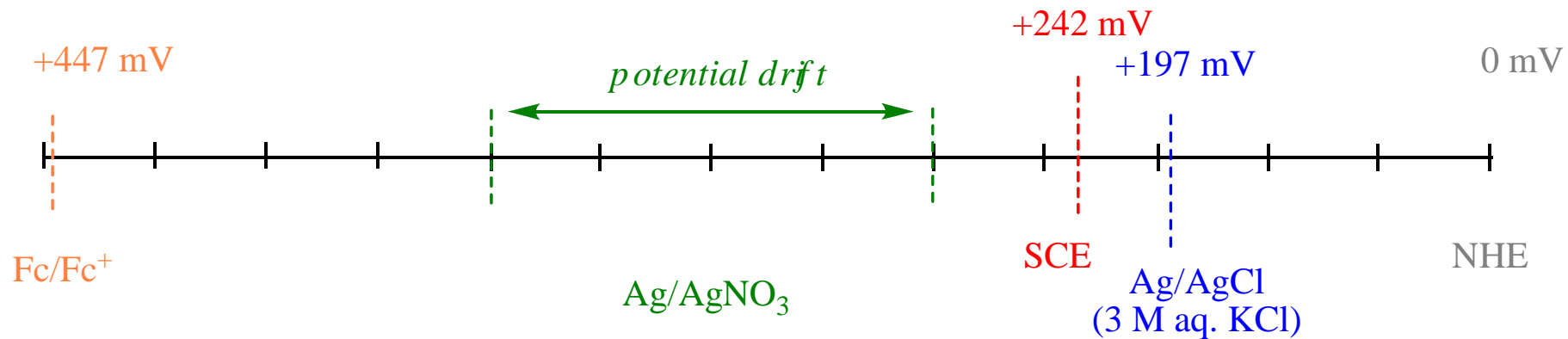

<i>Ref</i>	E_{pa}	E_{pc}	ΔE_p	$E_{1/2}$
Ag/AgCl	+0.48	+0.42	60	+0.45
NHE	+0.68	+0.62	60	+0.65
SCE	+0.53	+0.47	60	+0.47
Fc/Fc ⁺	+0.30	-0.30	60	+0.00