

Electrical Conduction

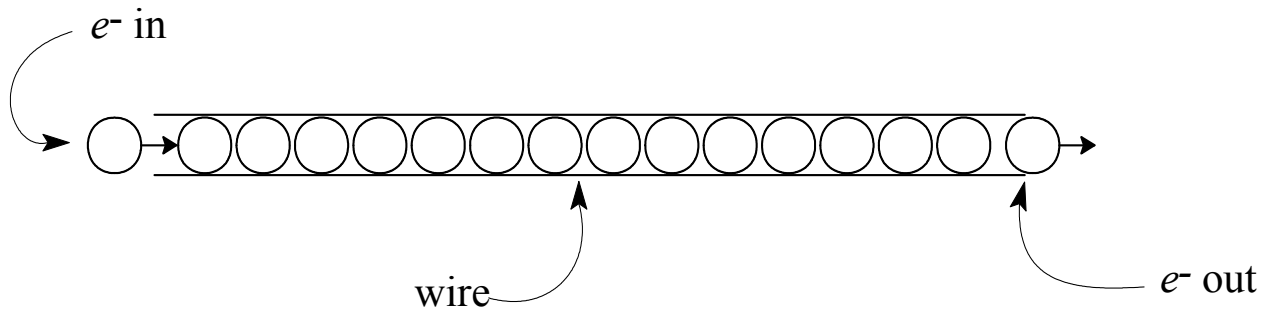

- ➡ **Electrical conduction** is the flow of electric charge produced by the movement of electrons in a conductor.
- ➡ The rate of electron flow (called the **current**, I , in amperes) is the amount of charge (in coulombs, C) carried per unit time:

$$I = Q/t$$

$$Q = It$$

$$1 \text{ C} = 1 \text{ amp}\cdot\text{s} = 6.24 \times 10^{18} \text{ unit charges}$$

$$\begin{aligned} \text{Faraday } (\mathcal{F}) &= 96,489 \pm 2 \text{ C} \approx 9.65 \times 10^4 \text{ A}\cdot\text{s} \\ &= \text{charge of one mole electrons} \end{aligned}$$

Electrolytic Conduction

- ☞ ***Electrolytic conduction*** is the passage of electrical current through an electrolyte (molten salt or electrolyte solution).
- Charge is carried by the movement of ions.
 - Electrolytic conduction results in *non-spontaneous* chemical change, called ***electrolysis***.
- ✓ No ions can move freely in solid ionic salts, so there can be no electrolytic conduction.
- ⇒ Ionic *solids* are non-conductors.
- ☞ **Electrolysis reactions are most often *non-spontaneous* redox reactions, forced to occur by the imposed electrical potential.**

Electrolysis Cell

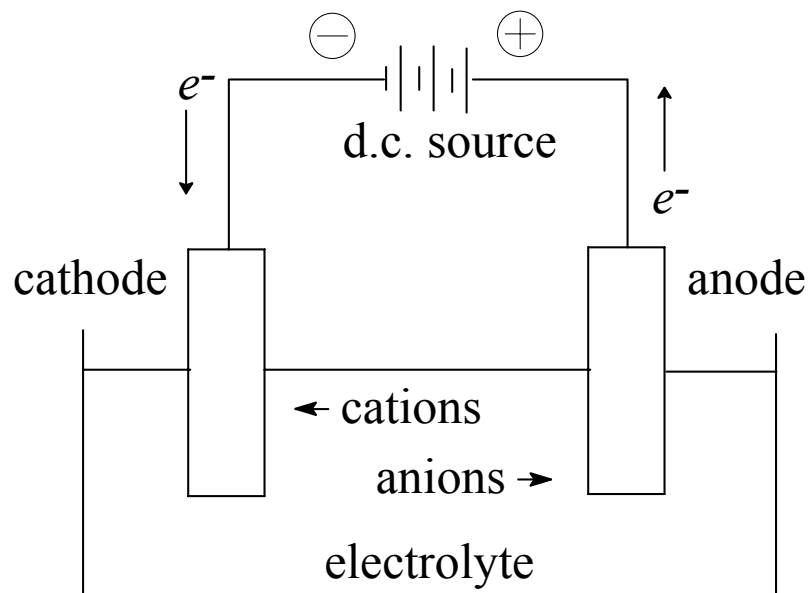

- Battery or other direct current (d.c.) source forces passage of electrical current through electrolyte.
- Cathode is electron source for species that are reduced in the electrolysis reaction.
- Anode is electron sink for species that will be oxidized in the electrolysis reaction.
- Cathode is negative (\ominus); anode is positive (\oplus).
- In the external circuit, electrons flow from the anode, through the d.c. current source, to the cathode.

Electrolysis of Molten $\text{NaCl}(l)$ With Inert Pt Electrodes

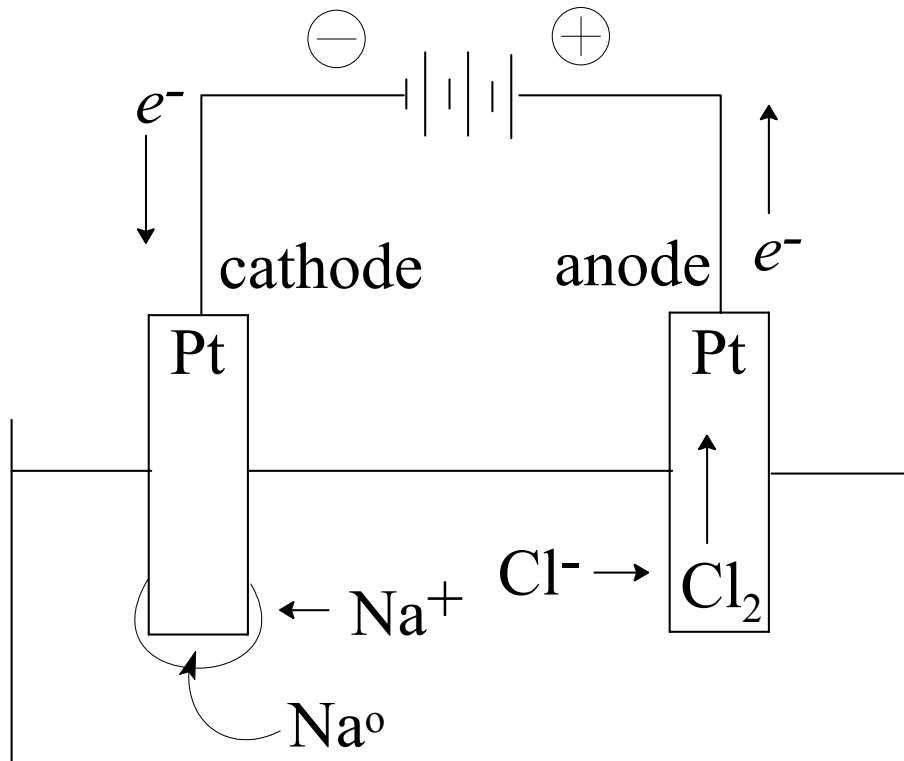

Electrolysis in Aqueous Solution



In an aqueous solution of an electrolyte, there may be several possible oxidations and several possible reductions.



Among possible oxidations and reductions, the overall redox reaction requiring the least applied voltage will occur.

Electrolysis of NaCl(aq) Solution With Inert Pt Electrodes

Possible Reductions at the Cathode:



☞ Reduction of $\text{H}_2\text{O}(l)$ requires overcoming much less potential, so formation of $\text{H}_2(g)$ and $\text{OH}^-(aq)$ occurs.

Possible Oxidations at the Anode:

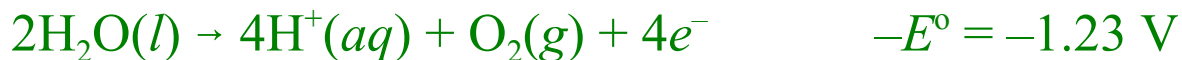

☞ Applied voltage requirements are similar, but formation of $\text{O}_2(g)$ at Pt has a high **overvoltage**, so $\text{Cl}_2(g)$ forms at high concentrations of $\text{Cl}^-(aq)$.

✓ **Overvoltage** is extra voltage that must be supplied to overcome a kinetic inhibition to forming a certain species at a particular kind of electrode.

Electrolysis of NaCl(aq) Solution With Inert Pt Electrodes

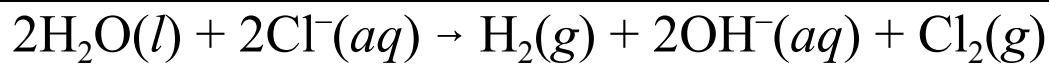
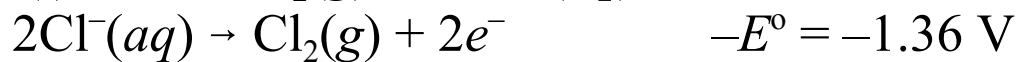
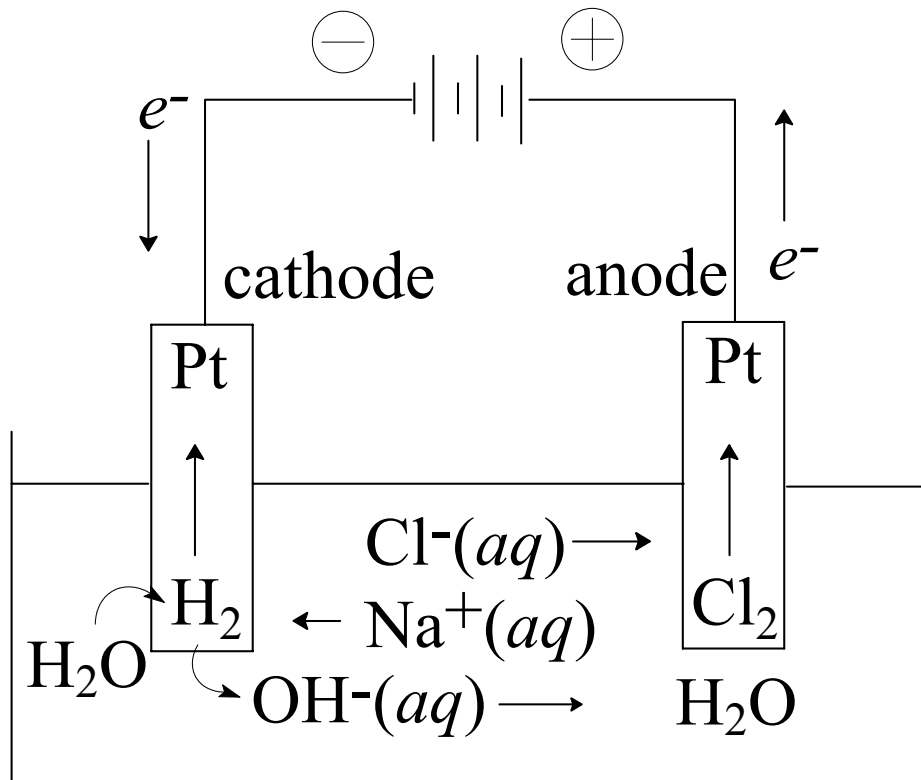

$$E^\circ_{\text{cell}} = -2.19 \text{ V}$$

Electrolysis of $\text{CuSO}_4(aq)$ Solution With Inert Pt Electrodes

Possible Reductions at the Cathode:



☞ $\text{Cu}^{2+}(aq)$ is reduced to $\text{Cu}(s)$.

Possible Oxidations at the Anode:

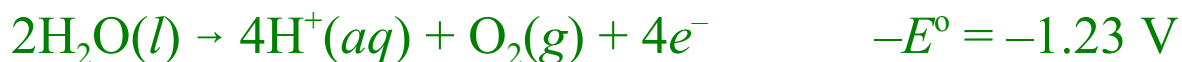
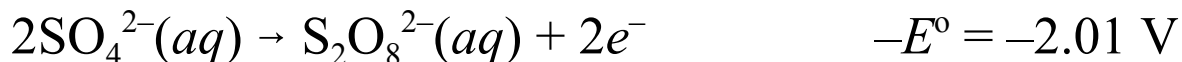

☞ $\text{H}_2\text{O}(l)$ is oxidized to $\text{O}_2(g)$ and $\text{H}^+(aq)$, despite the overvoltage.

Electrolysis of $\text{CuSO}_4(aq)$ Solution With Inert Pt Electrodes

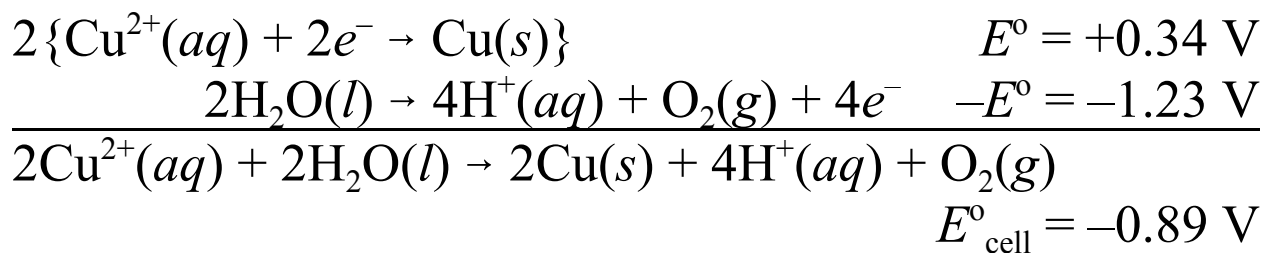
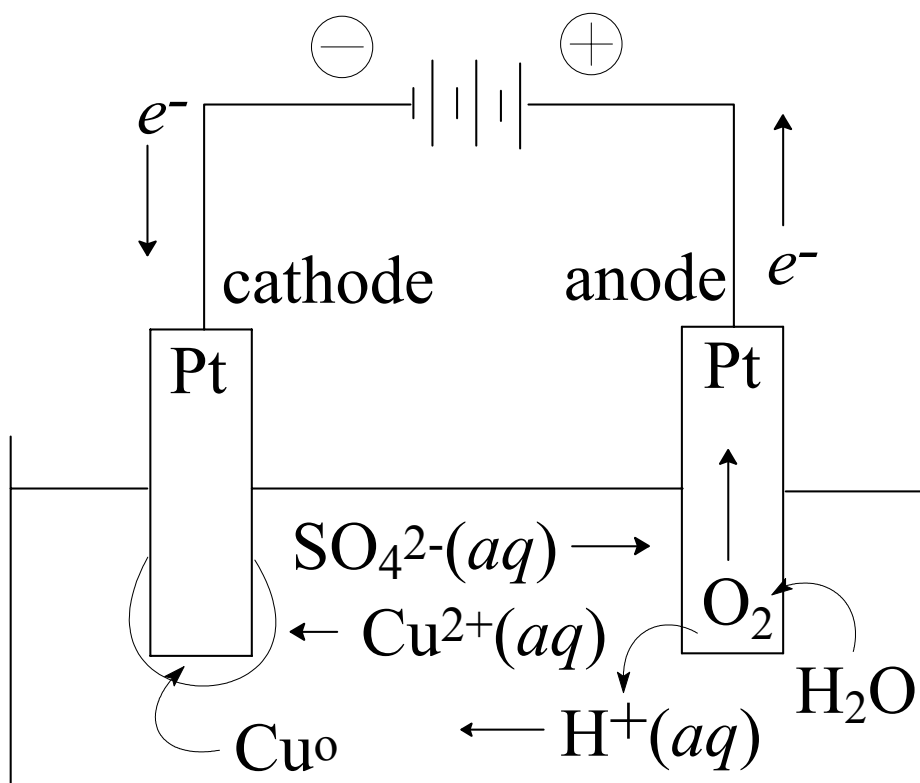

Electrolysis of $\text{CuSO}_4(aq)$ Solution With Active Cu Electrodes

Possible Reductions at the Cathode:



☞ $\text{Cu}^{2+}(aq)$ is reduced to $\text{Cu}(s)$.

Possible Oxidations at the Anode:

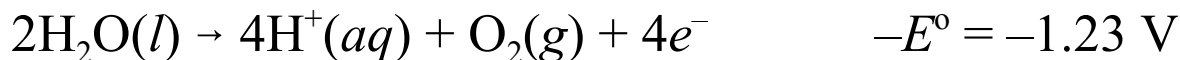
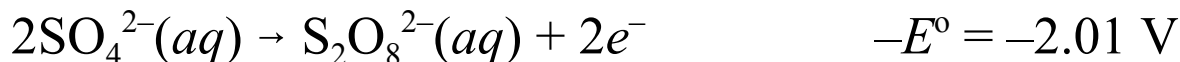

☞ Now $\text{Cu}(s)$ oxidation is the favored process at the anode, so $\text{Cu}(s)$ is oxidized to $\text{Cu}^{2+}(aq)$.

Electrolysis of $\text{CuSO}_4(aq)$ Solution With Active Cu Electrodes

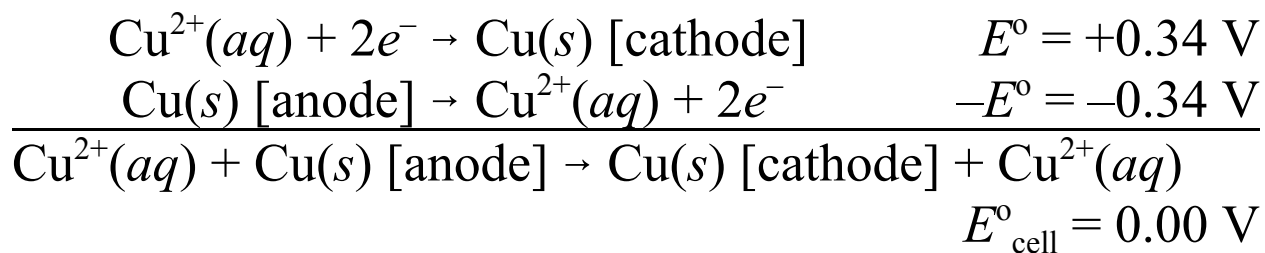
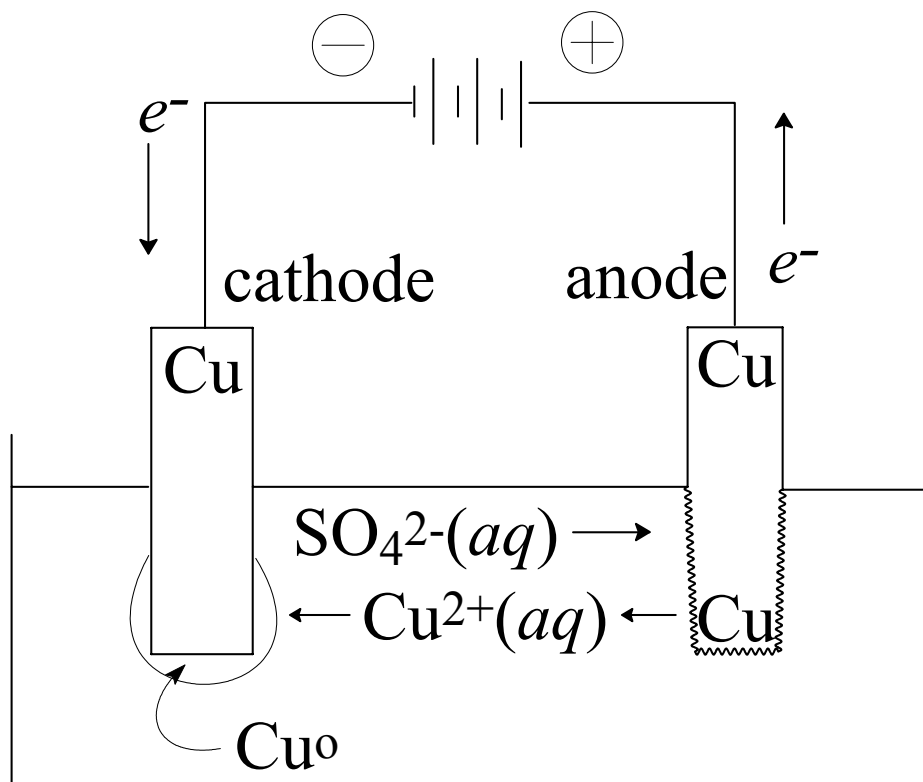

Faraday's Law

- ☞ The amount of substance produced or consumed at an electrode is proportional to the number of electrons transferred from the anode to the cathode.

$$Q = It$$

Faraday (\mathcal{F}) = $96,489 \pm 2 \text{ C} \approx 9.65 \times 10^4 \text{ A}\cdot\text{s}$
= charge of one mole electrons

- ☞ The *equivalent weight* of a substance is that amount produced or consumed at an electrode when the charge equivalent to one mole of electrons ($1 \mathcal{F}$) is passed.